



UNIVERSITY OF ILLINOIS
EXTENSION

Illinois Migrant Council

PREPARING A NEW GENERATION OF ILLINOIS FRUIT AND VEGETABLE FARMERS
a USDA NIFA BEGINNING FARMER AND RANCHER DEVELOPMENT PROGRAM PROJECT
GRANT # 2012-49400-19565

BASICS OF FRUIT INSECT MANAGEMENT

Rick Weinzierl, University of Illinois
weinzier@illinois.edu

July, 2014



Context and Objectives

- Previous presentations and discussions on pesticides, OMRI-approved pesticides, and integrated pest management
- Parallel presentations on vegetable insect management, weed, disease, and wildlife management
- Today: Describe the key insects and related pests of fruit crops and explain approaches to their management so that you can make decisions for effective pest management

Common pests of apples



- Direct pests (arthropods) include:
 - Plum curculio
 - Codling moth
 - Apple maggot
 - Oriental fruit moth
 - Stink bugs and plant bugs
 - Leafrollers (obliquebanded, red-banded, and tufted apple bud moth)
 - Asian multicolored lady beetle
- Indirect pests (arthropods) include:
 - San Jose scale
 - Spotted tentiform leafminer
 - White apple leafhopper, potato leafhopper
 - Rosy apple aphid, “green” aphids, and woolly apple aphid)
 - European red mite & twospotted spider mite
 - Dogwood borer
 - Japanese beetle

Common pests of peaches

- Direct pests (arthropods) include:
 - Plum curculio
 - Oriental fruit moth
 - Stink bugs and plant bugs
 - Japanese beetle
- Indirect pests (arthropods) include:
 - Peachtree borer
 - Lesser peachtree borer
 - San Jose scale
 - European red mite
 - Japanese beetle



Common pests of small fruits



- Direct pests (insects, other arthropods, and molluscs) include:
 - Blueberry maggot and plum curculio (in blueberries)
 - **Spotted wing Drosophila !!**
 - Eastern flower thrips
 - Gray garden slug
 - Japanese beetle
 - Stink bugs and plant bugs
 - Sap beetles
 - Grape berry moth
- Indirect pests (arthropods) include:
 - Strawberry clipper
 - San Jose scale
 - European red mite
 - Japanese beetle

Simplest response to these insects ...

- Do nothing
 - For peaches and apples in established areas, the result can be 70-100 percent loss (yield loss and infested, damaged, unmarketable fruit) for commercial production
 - For late-season raspberries ... the same result when spotted wing Drosophila is established
 - Lesser losses in strawberries and blueberries
- Backyard growers salvage some fruit by cutting out damaged portions ... not acceptable for commercial production

“Old” approach to managing these insects (overstated) ...

- Except during bloom, spray often enough to have a residue on the trunk, leaves, and fruit to kill anything that might be present at any time
 - Prebloom oil in apples and peaches
 - Insecticide(s) at pink, petal fall, and ~ every 2 weeks until near harvest in apples and peaches
 - Similar calendar-scheduled treatments in other fruits
- Problems
 - Costs, unwanted/illegal residues on fruit, insecticide resistance, destruction of natural enemies, control failures
 - Limitations on number of times specific insecticides may be used
 - No single insecticide currently controls all the pests that might be present at any time

Basic approaches to IPM for insects and related pests of most fruits

- Apply dormant / semi-dormant sprays of emulsifiable oils
- No sprays during bloom (some exceptions for small fruits)
- “Petal fall” and “cover” sprays in tree fruits (including OMRI-approved products)
- A few production / horticultural practices, including bagging apples
- Some biotic /biological control ... conservation by way of insecticide choices; augmentation of mite predators in high tunnels
 - Provision of pollen and nectar sources for predators and parasites yields mixed results in most fruit crops
- Sprays based on scouting / monitoring

References ... entomology in general

- Introduction to Applied Entomology (University of Illinois)

<http://cpsc270.cropsci.illinois.edu/syllabus/index.html>

<http://cpsc270.cropsci.illinois.edu/syllabus/lab09.pdf>

- **Garden Insects of North America.**

– W. Cranshaw. ISBN: 9780691095615
672 pp. 1,400+ color photos.

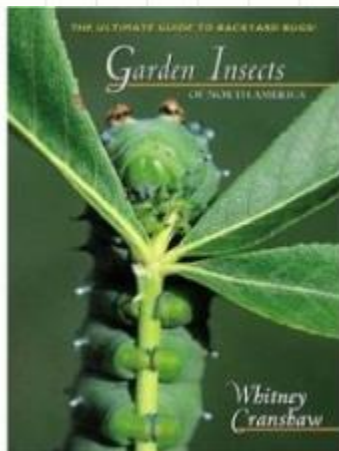

Illinois Migrant Council



References and Resources

- Field Guide for Identification of Pest Insects, Diseases, and Beneficial Organisms in Minnesota Apple Orchards
 - <http://www.mda.state.mn.us/plants/pestmanagement/ipm/apple-guide.aspx>
- Tree Fruit Field Guide to Insect, Mite, and Disease Pests and Natural Enemies of Eastern North America. ISBN: 1-933395-02-8. Order at: http://palspublishing.cals.cornell.edu/nra_order.taf?function=detail&pr_id=158&UserReference=4983462C15D28A6C4A201F4B
- Epstein et al. **Pocket Guides for IPM scouting in Apples and in Stone Fruits.** Order at http://msue.anr.msu.edu/resources/scouting_guides_for_fruit or view online at http://web2.msue.msu.edu/Bulletins/Bulletin/PDF/Historical/finished_pubs/e2720/e2720-2004.PDF and at http://www.oakgov.com/msu/Documents/publications/e2840_ipm_scoutingin_stonefruits.pdf

References on Small Fruit Insects

- Midwest Small Fruit Pest Management Handbook
 - <http://pested.osu.edu/documents/CommStudy/2b%20Midwest%20Small%20Fruit%20Pest%20Mgmt..pdf>
- Virginia Small Fruit IPM
 - <http://www.virginiafruit.ento.vt.edu/small-fruit-ipm.html>

From Identification to Pest Management

- Midwest Tree Fruit Pest Management Handbook
 - <http://www.ca.uky.edu/agc/pubs/id/id93/id93.htm>
- Midwest Small Fruit Pest Management Handbook
 - <http://pested.osu.edu/documents/CommStudy/2b%20Midwest%20Small%20Fruit%20Pest%20Mgmt..pdf>



Order from
<https://pubsplus.illinois.edu/FPM2.html>

Monitoring Insects and Mites

- Primary tools
 - Hand lens
 - Beating tray
 - Pheromone traps
- Guidelines
 - Start with the Apple IPM and Peach Pocket Guides listed above
- Sources of Equipment and Supplies
 - Great Lakes IPM, 10220 E Church Rd., Vestaburg, MI 48891 989-268-5693 or 800-235-0285 ...
<http://www.greatlakesipm.com/>

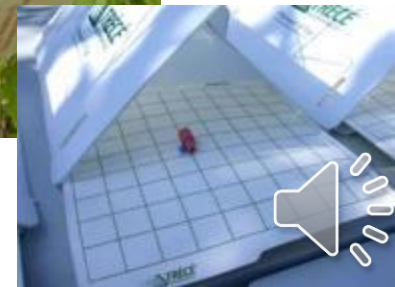

Pheromone Traps

- Using pheromone traps (and other insect traps)
 - A summary of insect trapping guidelines for tree fruit insects (for monitoring populations to determine the need for and timing of sprays) is provided at <http://ipm.illinois.edu/ifvn/contents.php?id=40#fruit>
 - Color ... orange or white for most moths (red sphere for apple maggot)
 - Type ... large delta trap for most moths
 - Lures ... differ for each species; do not combine in single trap
 - Always keep records of counts

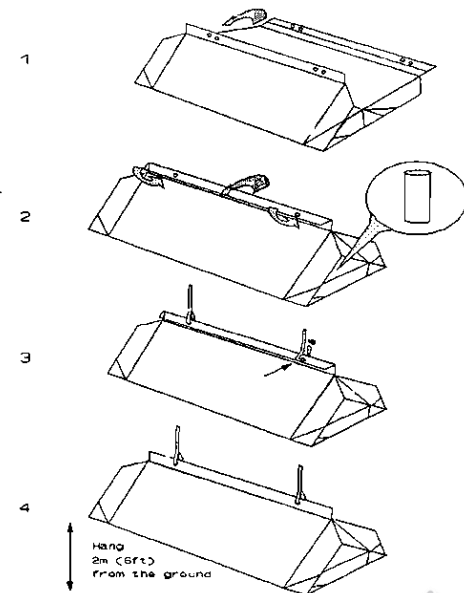

Insecticide & Fungicide Recommendations (tree fruits)

- Midwest Tree Fruit Spray Guide
 - <http://www.extension.iastate.edu/Publications/PM1282.pdf>
- Pennsylvania Tree Fruit Production Guide
 - <http://extension.psu.edu/fruit-production/tfpg>
- Cornell Pest Management Guidelines for Commercial Tree Fruit Production
 - <http://ipmguidelines.org/treefruits/>
- A Grower's Guide to Organic Apple Production
 - http://nysipm.cornell.edu/organic_guide/apples.pdf
- Pest Management for the Home Landscape
 - <https://pubsplus.illinois.edu/C1391-12.html>

Spray Guides for Small Fruits



- Midwest Small Fruit and Grape Spray Guide:
<https://ag.purdue.edu/hla/Hort/documents/ID-169-2013.pdf>

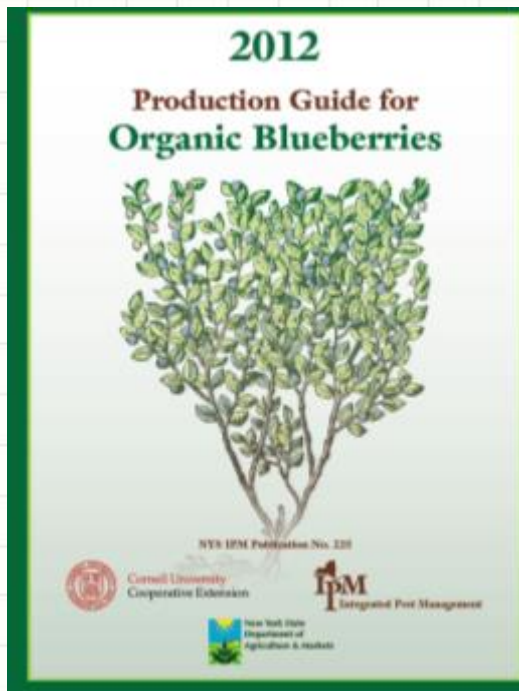

- Cornell Organic Production Guides (blueberries, grapes, strawberries)
http://nysipm.cornell.edu/organic_guide/

So, for apples and peaches ...

- Superior oil for San Jose scale, European red mite eggs, and rosy apple aphid eggs (apples) between green tip and bloom
- An insecticide that is effective against plum curculio and (sometimes) stink bugs / plant bugs (peaches) at petal fall
- Additional sprays or mating disruption as indicated by traps and “scouting”

Apples ...

Prebloom in apples... Oils at green tip to pink suffocate insect stages that are coated with spray

- Dormant oil / superior oil at 2 percent by volume early, decreasing to 0.5 to 1 percent by volume at pink
- Controls San Jose scale, rosy apple aphid eggs, and red mite eggs
- Successive applications of oil in this period improve control
- Not harmful to beneficials at this time. No cross-resistance or resistance management issues
- Most superior oils are approved for use in organic production
- May add Lorsban, Supracide, or Diazinon to improve scale and aphid control, but oil alone is very effective
- May add Esteem for increased scale control, but later application against crawlers is also effective.
- Early timing (green tip) is best for scale control; later timing (half-inch green to pink) is better against European red mite and rosy apple aphid



Bloom

- Hang codling moth pheromone traps
 - Order from Great Lakes IPM, Suterra, or Gempler's
 - Use at least 3 in an orchard or community; then 1 per 5 acres up to 10 – 12 traps per farm
- Hang codling moth mating disruption dispensers or begin applications of other formulations if mating disruption is to be used against codling moth
 - Effective only in orchards, not isolated trees
 - Use additional 10x lures in traps to measure success of mating disruption

Pheromones for mating disruption in apples

- “Twist-tie” dispensers
- Sprayable pheromones
 - CheckMate CM from Suterra, Certis markets 3-M’s sprayable pheromones
- All pheromone products are effective against only the target species. Specific products are available to disrupt mating of **codling moth, oriental fruit moth**, grape berry moth, and the **peachtree borers**.

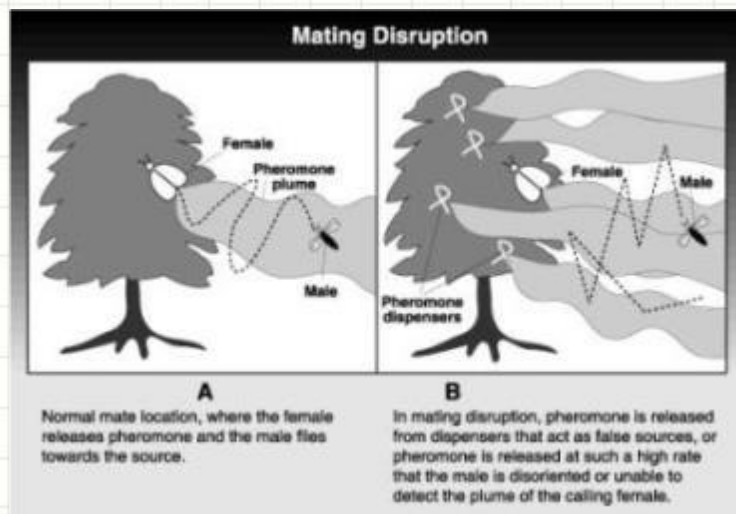



Pheromone dispensers
used for mating disruption.



Petal fall in apples

- Plum curculio is key target ... make spray decisions on prior experience and proximity to woods.
 - Effective insecticides include: Avaunt, Imidan, Assail (also some pyrethroids, but they trigger mite outbreaks ... see Spray Guide). Organic growers use Surround.
- Monitor traps for codling moth
- Scout for rosy apple aphid, plant bugs, European red mite
- See Tree Fruit Pest Management Handbook for additional scouting details

Plum curculio

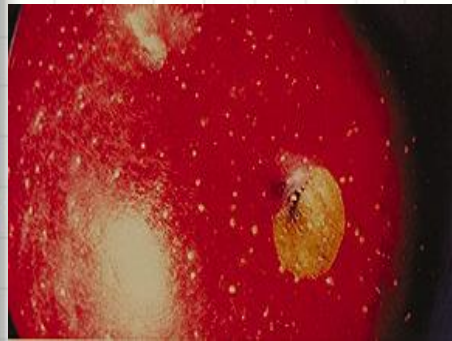

Reported Status of
PLUM CURCULIO, *CONOTRACHELLUS NEMIPHAR*
in US and Puerto Rico
Data retrieved from National Agricultural Pest Information System on 2009-01-23

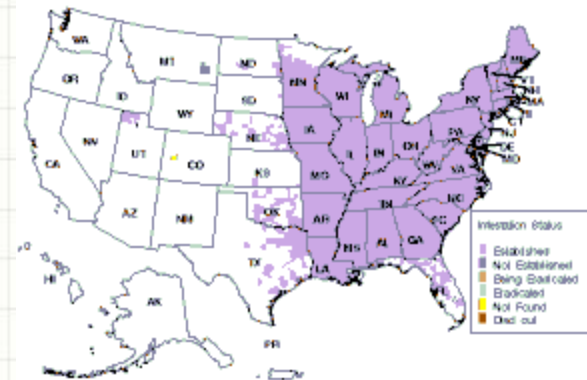

The Center for Environment and Regulatory Information Systems does not verify the accuracy or completeness of the map.
Negative data spans over last 3 years only.

Imidan, Assail, and Avaunt are products of choice for PC control at petal fall (and sometimes first cover) ... organic growers may use Surround plus Pyganic

Codling moth



- Introduced to North America over 200 years ago.
- Mature larvae overwinter in silken cocoons under loose bark and on packing crates in warehouses. They pupate in the spring, and moths emerge during bloom and petal fall.
- Females lay eggs on twigs, leaves, and developing fruits. Larvae hatch, crawl to a fruit, chew through the skin, and tunnel to the core to feed on seeds. 2-3 generations per year.
- The standard approach to control is to use insecticides as "cover sprays" so that residues are present on fruits when codling moth larvae are hatching. Organophosphate insecticides such as Guthion and Imidan (and others) were used since the 1960s for this purpose, but codling moth populations in many areas are now resistant to these insecticides. Newer and safer insecticides now include Assail, Calypso, Rimon, Delegate, Altacor, and Belt. Entrust is an OMRI-listed formulation of spinosad, and codling moth granulosis virus is sold as Cyd-X and other formulations.
- **Backyard growers ... see Home Pest Control Guide.**



- Key steps in timing the use of insecticides for codling moth control include the use of pheromone traps and degree day models. Traps baited with lures containing a synthetic mimic of the sex pheromone that females produce to attract males are placed in orchards when trees begin to bloom ... at least 3 traps per orchard (or community).
- Check traps at least twice weekly, and when they begin to consistently catch moths (at least an average of 2 per trap in a week's time), use that date as the "biofix" for that orchard.
- Egg hatch begins 220-240 DD after moth flight began (the biofix date). Insecticides are applied to (1) place a residue on the surface of fruit before eggs are laid if the insecticide's effectiveness depends on poisoning newly laid eggs, or (2) place a residue on the surface of fruit by the time eggs hatch.
- Most insecticides applied to tree fruits provide an effective residue for around 2 weeks, and the need to reapply can be based on looking back at trap captures and degree-day accumulations to determine if protecting the fruit is necessary.
- Mating disruption is an alternative in orchards.

Degree days

- See ...

- <http://ipm.illinois.edu/degreedays/>
- <http://ipm.illinois.edu/degreedays/calculator.html>
- <http://www.sws.uiuc.edu/warm/pestdata/sqlchoose1.asp?plc=>



Choose a pest.

- [Alfalfa weevil](#)
- [Apple maggot](#)
- [Armyworm](#)
- [Bean leaf beetle](#)
- [Black cutworm](#)
- [Cereal leaf beetle](#)
- [Codling moth](#)
- [Colorado potato beetle](#)
- [Corn earworm](#)
- [Corn flea beetle](#)
- [Corn leaf aphid](#)
- [Corn rootworm](#)
- [Emerald Ash Borer](#)
- [European corn borer](#)
- [European red mite](#)
- [Fruit tree leafroller](#)
- [Green cloverworm](#)
- [Lilac borer](#)
- [Mexican bean beetle](#)
- [Oriental fruit moth](#)
- [Peachtree borer](#)
- [Potato leafhopper](#)
- [San Jose scale](#)
- [Seedcorn maggot](#)
- [Southwestern corn borer](#)
- [Spotted tentiform leafminer](#)
- [Squash vine borer](#)
- [Stalk borer](#)
- [Tufted apple bud moth](#)
- [Two-spotted spider mite](#)
- [Western bean cutworm](#)

Click the nearest station (dot).



CALCULATE

Clear Selection

From a mid-July, 2013, issue of the *Illinois Fruit and Vegetable News*.

Codling moth: Based on the biofix dates for the locations listed below, degree-day accumulations (base 50F) since biofix for each location (based on the closest regional weather stations) are ...

Location	Biofix Date	Degree-Days base 50F, through July 14	Degree-Days base 50F, projected through July 21	Degree-Days base 50F, projected through July 28
Murphysboro	May 4	1502	1693	1882
Belleville	May 10	1428	1619	1807
Centralia	May 15	1401	1598	1792
Urbana	May 17	1237	1418	1597
Lake County	May 19	1030	1184	1335

Based on current forecasts for high temperatures, expect degree-day accumulations over the next several days to exceed the projections in the table above (based on historic averages for this period). Some key events in the codling moth's life cycle in comparison with degree-day accumulations (based on Table 6, p. 260, in *Orchard Pest management, A Resource Guide for the Pacific Northwest*, by Beers et al, published by the Good Fruit Grower in 1993) ...

Degree-Day Accumulations (Base 50 F)	Second-Generation Flight	Second-Generation Egg hatch	Third-Generation Flight	Third-Generation Egg Hatch
1,200	26 percent complete	3 percent complete		
1,300	43 percent complete	10 percent complete		
1,500	77 percent complete	36 percent complete		
1,600	85 percent complete	53 percent complete		
1,700	92 percent complete	69 percent complete		
1,800	97 percent complete	81 percent complete		
1,900	100 percent complete	88 percent complete		
2,000		95 percent complete	4 percent complete	
2,200		100 percent complete	20 percent complete	3 percent complete

See the [2013 Midwest Tree Fruit Spray Guide](#) for listings of effective insecticides for codling moth control; they include Assail, Calypso, Altacor, Belt, Delegate, and Rimon. Entrust and codling moth virus products are available

San Jose scale



- Increasing problems in several orchards in recent years (even in managed orchards)
- Why?
 - Long-term population density cycle on other hosts?
 - Discontinued use of certain insecticides after bloom

Control with superior oil before bloom!!

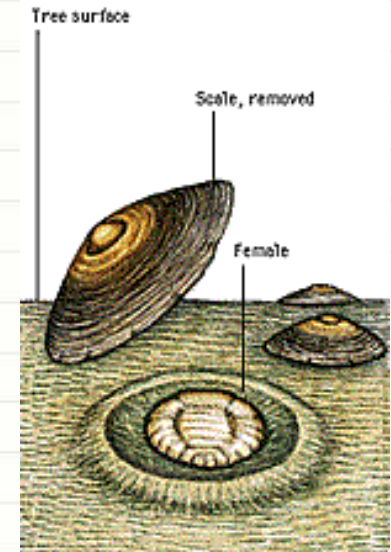

Immature males and females overwinter under scales, and males emerge and fly to females around bloom. Females give birth to live nymphs under the protective cover of the scale. Crawlers become active a few weeks later.

Control of San Jose scale crawlers

- Crawler activity begins around 4-6 weeks after bloom; monitor with black sticky tape where infestations were apparent the previous year
- Insecticides include
 - Movento (**Group 23**)
 - Esteem (**Group 7**)
 - Assail (**Group 4A**)
 - Centaur (**Group 16**)
 - Diazinon (**Group 1B**)



Apple maggot



- Found in eastern North America, not south of I-70 in IL
- One generation per year
- Monitor (“trap out” in back yards) with sticky-coated red spherical traps
- Easily controlled with “cover sprays” as needed

Organics

- Mating disruption against codling moth
- Codling moth virus against codling moth
- Entrust against codling moth (fair at 7- to 10-day intervals), apple maggot, STLM, leafrollers
- GF-120 (same ingredient as in Entrust) as a bait for apple maggot control
- BT (Dipel and others) against leafrollers
- Oils against San Jose scale, mites, and aphids
- Neemix and pyrethrins against Japanese beetle
- Bagging individual fruits excludes direct pests



Key concerns in peaches



- Oriental fruit moth
 - Monitor with traps ... just as for codling moth
 - Pyrethroid resistance confirmed in Calhoun County
 - Alternatives
 - Mating disruption
 - Altacor or Belt, Assail (not Calypso), Delegate, Rimon, Imidan

- Stink bugs and plant bugs

- Usually controlled by sprays of pyrethroids (Asana, Baythroid, Mustang Max, Pounce, Warrior, and their generics) ... no really effective organic products available



Over 45 stink bug species occur commonly throughout North America. *Euschistus servus* (upper left), *Euschistus variolarius* (upper right), and *Euschistus conspersus* (lower left), all of which are brownish, are often-cited pests of a variety of crops.



Brown marmorated stink bug

- *Halyomorpha halys*
- Introduced (NOT intentionally) from Asia, first detected in Allentown, PA, in 1998
- Now established as far west as OH, KY, and IN
- Overwinters as an adult, aggregates in large numbers in homes and other shelters
- Expect 2 generations per year in most of IL

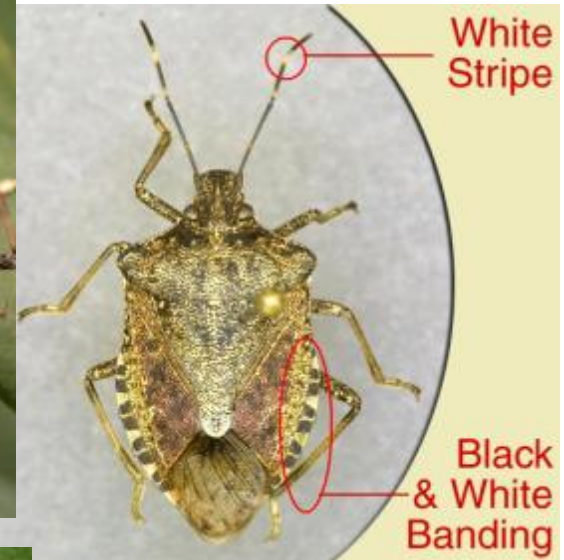
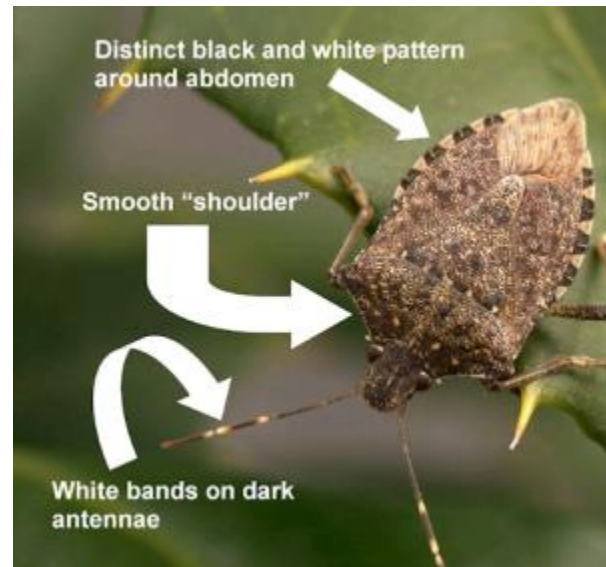

Brown marmorated stink bug

- Severe damage to apples, peaches, tomatoes, sweet corn, many other crops
- Many noncrop hosts serve as reservoirs for population buildup
- Very difficult to control ... pyrethroids kill nymphs and adults present at the time of application



<http://ento.psu.edu/extension/factsheets/brown-marmorated-stink-bug>
http://ohioline.osu.edu/hyg-fact/pdf/FS_3824_08.pdf



Peachtree borer and lesser peachtree borer



Adults are “clearwing moths”.
Larvae are caterpillars that tunnel
beneath bark and girdle trunks
and limbs.



Lesser peachtree borer monitoring and control

- Hang pheromone traps (4 to 5 feet high) by late April
- Where damage has been severe, apply two trunk sprays per year
 - First application 7 to 10 days after flight begins in spring
 - Second application when flights peak again in August or early September (or shortly after harvest is complete)
 - Spray trunks and scaffold branches to run-off but do not treat fruit
 - Lorsban 4EC (50W not labeled for peaches)
 - Asana, Ambush / Pounce, Warrior
 - Where damage has been light, one spray per season (in May) may be adequate

(Greater) Peachtree borer monitoring and control



Peachtree borer male on pheromone trap

- Hang pheromone traps (3 ft above ground) by late May or early June
- Record counts twice weekly to determine time of peak flight
- Apply trunk sprays
 - 10 days after moth flight begins (late June)
 - Just after flight peaks (August)
 - The August application alone is adequate if pressure is light to moderate
- Or use Isomate PTB Dual for mating disruption to control peachtree borer and lesser peachtree borer

Small fruits

Spotted wing Drosophila



- Native to East Asia, where it is a pest on fruit.
- Detected in CA in 2008, OR, WA, BC, FL in 2009, UT, SC, NC, MI, WI in 2010
- Widespread in IL surveys in 2012 ... damage primarily to fall raspberries ... outdoors and in high tunnels



Crops at greatest risk are strawberries, raspberries, cherries, nectarines, blueberries, and blackberries.

Other fruits that may be infested include peaches, grapes, [pears, apples, and tomatoes, as well as the berries of plants such as snowberry, elderberry, pokeweed, and dogwood.

Monitoring SWD



- Plastic cup with side holes, with (a) apple cider vinegar bait, (b) yeast-plus-sugar-water bait, or (c) commercial lures; see <http://ipm.illinois.edu/ifvn/contents.php?id=43> and <http://ipm.illinois.edu/ifvn/contents.php?id=44>
- Add a small yellow sticky trap to capture flies. Or, use only the bait with a drop of unscented soap.
- Hang in fruit canopy near fruit and in the shade.
- Change liquid weekly, and dispose away from trap.
- Best detection potential expected as fruit ripens.
- Check weekly, and record catches.



SWD identification

MALE

FEMALE

two rows of serrations on ovipositor

no dark spots on wings

M. Hauser, UC

M. Hauser, UC

dark spot on each wing

two dark bands on each foreleg



SWD Insecticides

- **Brambles**
 - Brigade (3), Danitol (3), Delegate (1), Entrust (1), Hero (3), Malathion (1), Mustang Max (1)
- **Strawberries**
 - Assail (1), Brigade (0), Danitol (2), Entrust (1), Malathion (3), Radiant (1)
- **Blueberries**
 - Asana (14), Assail (1), Brigade (1), Danitol (3), Delegate (3), Entrust (3), Hero (1), Imidan (3), Lannate (3), Malathion (1), Mustang Max (1)
- **Peaches**
 - Asana (14), Assail (7), Baythroid (7), Danitol (3), Delegate (14), Entrust (14), Imidan (14), Lannate (4), Malathion (7), Mustang Max (14), Pounce (14), Warrior (14)

Numbers in parentheses indicate required preharvest interval. See the Midwest Small Fruit Spray Guide, the Midwest Tree Fruit Spray Guide, and product labels for more information

Eastern flower thrips



Eastern flower thrips

- Eastern flower thrips do not overwinter outside of greenhouses in Illinois
- Populations are introduced each spring on winds / storm fronts from the south; may occur with the immigration of potato leafhopper
- Timing and magnitude of each spring's introductions determine severity of injury in strawberries
- Several generations develop each summer after thrips are introduced to the region
- Hot, dry conditions favor greatest population increases in summer and subsequent infestations of brambles

Annual northward migrations ...

“Aerial Plankton”

- Black cutworm
- Potato leafhopper
- Eastern flower thrips
- Corn earworm
- Corn leaf aphid
- Beet leafhopper
- Aster leafhopper
- Others

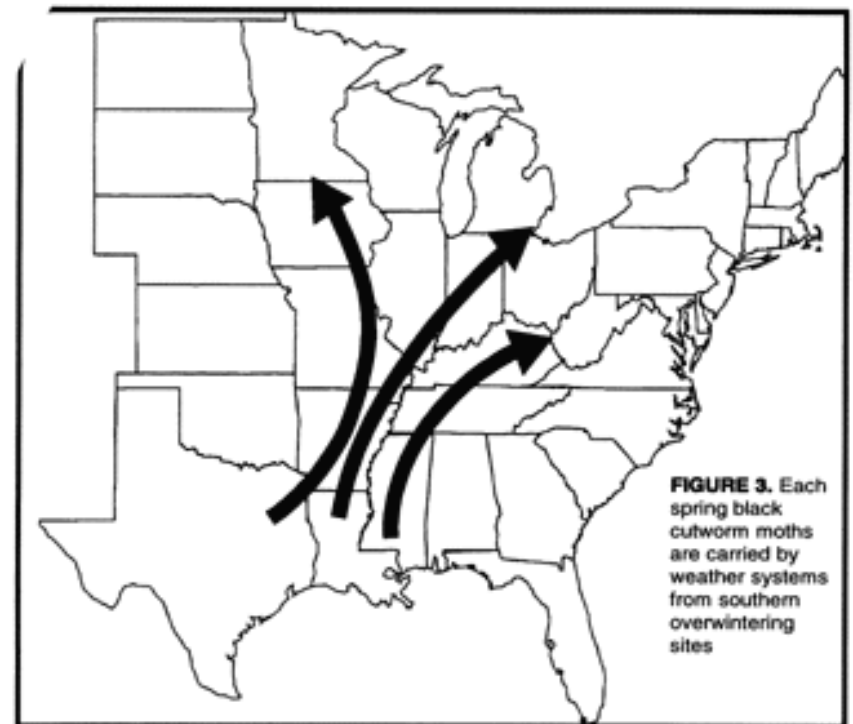

Thrips injury



- Seedy berries that do not size or color; tough, small, brown berries; little flavor
- Reported in the early 1900s, then not noted in Illinois records until 1990s; sporadic since then
- “Damage threshold,” based on separate reports from Ontario and from California, estimated at 2–10 thrips per blossom
- Injury may occur at blossom stage or on small berries

Monitoring thrips to determine need for control

- 2-10 per blossom or small berry
- Sampling
 - 10 blossoms per site; 10 or more sites per variety (a best guess in the absence of a statistically based program)
 - Sample different varieties separately, beginning as soon as the first blossoms open
 - Shake blossoms in a white cup or a white bowl or a zip-lock sandwich bag (can add 2 drops nail polish remover / ethyl acetate to kill them, but then they don't move ... well, duh!)

Thrips control recommendations

- Entrust (1), **SpinTor** (1), and Radiant (1) are labeled specifically for thrips control on strawberries.
- Endosulfan (4), Lorsban (21), Brigade (0), and Danitol (2) are labeled on strawberries and also should be effective
- Discontinue sprays after all harvestable berries have reached dime size
- Obey PHIs, REIs

(Numbers in parentheses indicate the required preharvest interval – PHI). See the annual Midwest Small Fruit and Grape Spray Guide

Gray garden slug in strawberries

- Scout before fruit is ripe
 - Board or burlap “traps” or beer cups for monitoring
 - Slug baits
 - Deadline metaldehyde
 - ProZap metaldehyde
 - Sluggo iron phosphate
 (OMRI-approved)
- Apply baits before ripe berries are present



*Photo courtesy of
MAFRI, Soils and Crops Branch*



For slugs in strawberries, remember ...

- Slugs that damage fruit this spring hatched from eggs laid in strawberry plantings last fall.
- Conditions that favor slug survival in summer and fall include abundant moisture and continuous presence of mulches.
- Cultural controls include removal of mulch after harvest, summer renovation, removal of plant debris, and waiting as long as practical to apply mulch in the fall.

Japanese beetle

- Adults feed on the leaves and fruits of over 275 (400) plant species
- Larvae feed on the roots of grasses, and are serious pests of turf in eastern states



An “introduced” pest (an exotic, invasive species)



- Detected in New Jersey in 1916
 - Slightly earlier introduction suspected
- Extremely high populations can occur a few years after establishment

Japanese beetle life cycle

- Larvae overwinter in soil, move nearer the surface in spring, feed on grass roots
- Pupate in May and June
- Adults emerge in June and July
- Females begin laying eggs in the soil in July, completing several cycles of feeding and egg laying
- Adults may be present through August and early September

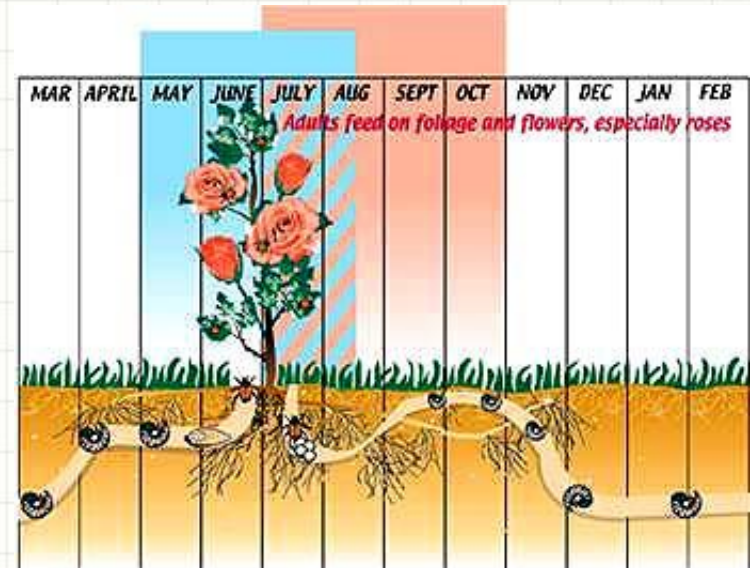

Adult Japanese beetles eat foliage and fruits



- Feed on fruits and foliage of
 - Grapes
 - Blueberries
 - Brambles
 - Peaches
 - Apples
 - (and lots of other crops)

Traps for Japanese beetles

- Lures are combination of sex attractant and “food odor”
- Generally not very effective at reducing damage ... too many beetles to “trap out”



Insecticides for Japanese beetle control

- Sevin, Imidan, Danitol, Capture, Brigade, Assail, Avaunt, Besiege, Neem, Pyganic
- Monitor for reinfestation; adult females are very mobile as they alternate between feeding and laying eggs
- Retreat as needed
- Follow precautions for protecting bees

Insecticides ... choosing a small number of conventional insecticides for small-scale commercial growers. (See labels re: specific crops.)

- General use, broad-spectrum insecticides: Superior oil, Sevin, Imidan, and a pyrethroid (see below)
- For codling moth and oriental fruit moth: Assail and/or Delegate
- For stink bugs: a pyrethroid (“Restricted Use – requires a Private Applicators License) (Mustang Max or Danitol or Warrior)
- Maybe a miticide, probably Acramite (or use ≤ 0.5 percent v/v “summer oil”)

Insecticides ... conventional insecticides for backyard growers

- Importance of “Not for Commercial Use”
 - General use, broad-spectrum insecticides:
 - Superior oil
 - Sevin – carbaryl
 - Malathion
 - For stink bugs:
 - Bonide Eight is permethrin – a pyrethroid
 - For codling moth: Spinosad –
 - Conserve
 - Gardens Alive sells Bulls Eye Bioinsecticide
 - Bonide sells Captain Jack’s Deadbug Brew
 - MPFS – malathion, carbaryl, and captan
 - And some of the organic products listed next

Insecticides ... OMRI insecticides for small-scale organic growers

- Mating disruption against codling moth and peachtree borers ... 1/4-acre orchard or greater
- Codling moth virus against codling moth
- Entrust or another spinosad product against codling moth (fair at 7- to 10-day intervals), apple maggot, STLM, leafrollers
- GF-120 (same ingredient as in Entrust) as a bait for apple maggot control
- BT (Dipel and others) against leafrollers
- Oils against San Jose scale, mites, and aphids
- Neemix and pyrethrins against Japanese beetle
- Bagging individual fruits excludes direct pests
- Mycotrol and similar fungal insecticides ... not well matched to pest spectrum

Natural enemies (predators and parasites) and pollinators

- For general information, see
 - <http://www.youtube.com/watch?v=r1EYCevAgnY>
 - <http://www.ncipmc.org/glvwg/pdfs/NaturalEnemiesFlyer-FINAL.pdf>
- For information on plants that enhance natural enemy abundance:
 - Growing Plants to Attract Beneficial Insects (<http://www.colostate.edu/Depts/CoopExt/4DMG/PHC/benefici.htm>)
 - Attracting Beneficial Insects with Native Flowering Plants (<http://nativeplants.msu.edu/uploads/files/E2973.pdf>)
 - List of pest-repelling plants (http://en.wikipedia.org/wiki/List_of_pest-repelling_plants)
 - High Value Pollinator Plants (http://www.nrcs.usda.gov/Internet/FSE_DOCUMENTS/nrcs141p2_029849.pdf)

Continuing Education ... newsletters

- Illinois Fruit and Vegetable News
 - <http://ipm.illinois.edu/ifvn/>
- Facts for Fancy Fruit ... Purdue's fruit newsletter
 - <http://www.hort.purdue.edu/fff/fff.shtml>
- Penn State Fruit Times
 - <http://extension.psu.edu/fruit-production/news>
- Rutgers (New Jersey) Plant and Pest Advisory
 - <http://njaes.rutgers.edu/pubs/plantandpestadvisory/>
... choose the month and year of interest (or review many of them) and under "All Editions" select Fruit.
- Scaffolds (Cornell, New York)
 - <http://www.scaffolds.entomology.cornell.edu/>

To reach me

Contacts

Rick Weinzierl

Contact information

weinzier@illinois.edu

Illinois Migrant Council

